



SECURITRON MODEL XMS EXIT MOTION SENSOR INSTALLATION AND OPERATING INSTRUCTIONS

1. DESCRIPTION

The XMS is a passive infrared motion detector specifically designed to **release a magnetic lock** from the inside for **free egress**. Unlike burglar alarm type detectors, the XMS has special features appropriate to this use. The **lock control function is fail safe** so that the magnetic lock will safely release if power is cut to the detector. A **relay** is also present to send a **REX** (request to exit) signal to an access control system (if one is present) and therefore shunt an alarm report. A **time extension** feature avoids the problem of the unit resetting if a person momentarily stops moving just before exit. **Tight control** of the exit detection **pattern** allows maximum security from the outside and avoidance of inadvertent activation from the inside.

Since egress from a magnetically locked door can be a safety issue, make sure you are **complying with local building codes**. Contact your **building and/or fire prevention department**.

2. PHYSICAL INSTALLATION

2.1 PLACEMENT OF THE UNIT

The XMS is intended for **indoor use** only. It is positioned with respect to the inside of the door so that its detection pattern will "see" a person approaching the door while maintaining good security from the outside. There are different options as to where the unit is placed depending on variables in the application.

FIG. 1: PLACEMENT OPTIONS FOR THE SENSOR

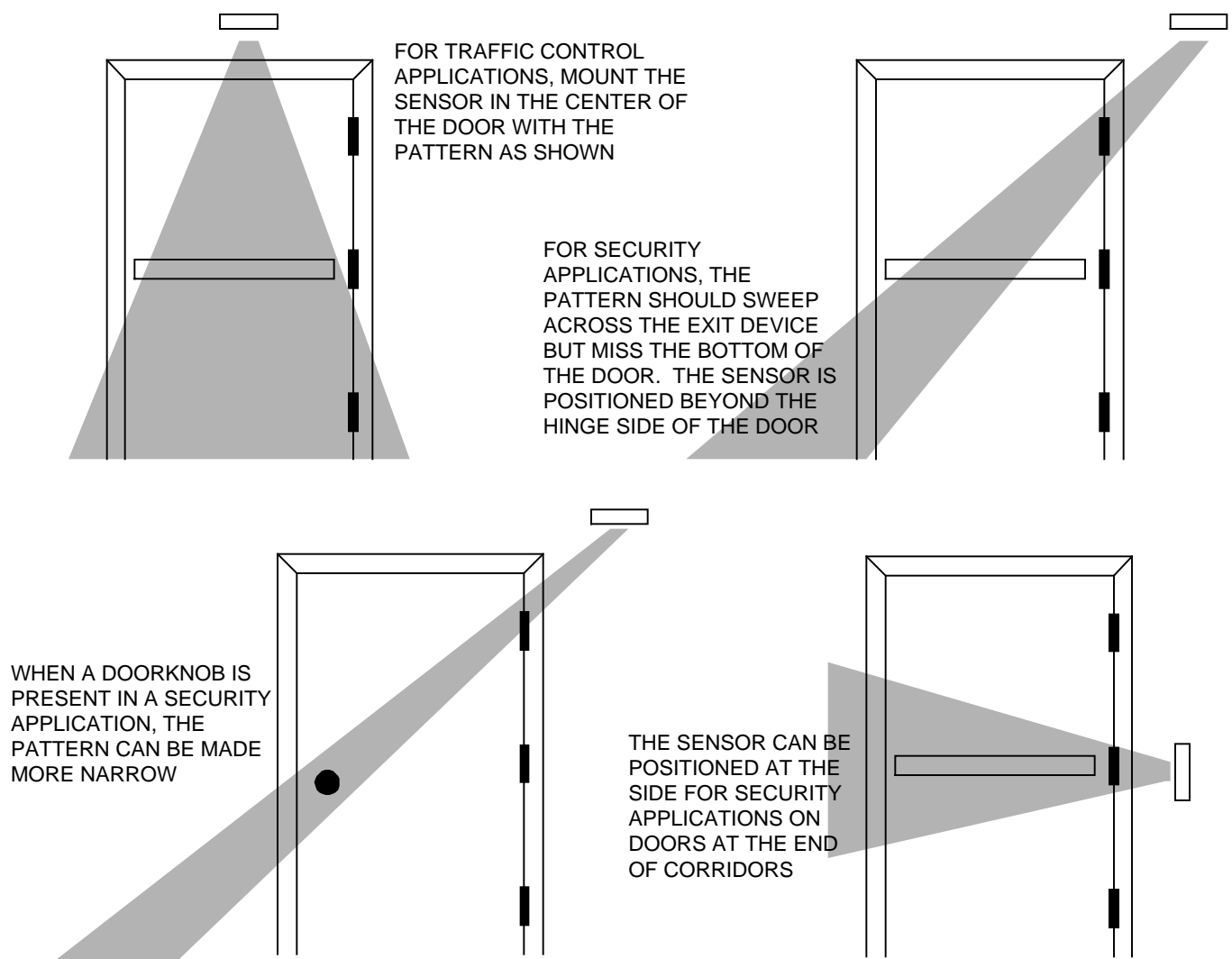

The simplest method of placing the unit is for **traffic control** applications. A traffic control application is one where you do not expect any attempt at breaking in from the outside. The unit is simply centrally positioned above the door with the pattern covering the door (setting the pattern is addressed later in this manual).

For **security** applications, you will set your position to defend against someone activating the detector from the outside. This can be done by inserting a heated object under the door. To deal with this threat, the unit is positioned above and outside of the door hinges with the pattern adjusted so that it sweeps across the door but does not detect the bottom of the door. If the door includes an exit bar, the pattern must be **broad** as a person's approach to the door is variable. If it includes a door knob or lever handle, the pattern can be adjusted **more narrowly**.. A final option for security applications is to position the unit at the side of the door so that it sees across the door. This can be used for doors at the **end of corridors**. You would not want to employ this approach for non corridor doors as the door would be released by someone walking near it (maximum detection range is 20-25 ft.) Side of door mounting has the disadvantage of greater exposure to vandalism but defends against objects being inserted under the door and provides excellent coverage along the full width of the door. Note that for the end-of-corridor application, the unit can be positioned on the same wall plane as the door or on a wall which is next to the door and perpendicular to it. You have the choice because the pattern can be adjusted a full 90 degrees with respect to the sensor's mounting plane.

2.2 FIXING THE UNIT TO THE WALL

First, locate the screw on the end of the unit and loosen it. This permits you to remove the cover. The appearance of the interior is shown in Figure 2. Note that the interior electronics is mounted on a rotating barrel which is locked by the "Barrel Locking Screw" shown in Figure 2. Loosen this screw and rotate the barrel fully upward so that you can remove it. This leaves you with the back piece and you will see two slotted holes for physical mounting and a choice of two wire entry points (also shown on Figure 2). Most installers prefer to pull the cable through the wall first and then mount the unit. If you're not sure of your wire count for the cable, consult the next section at this time but completion of physical installation consists only of screwing the back piece to the wall and pulling the cable through one of the wire entries. Then you will replace the barrel assembly and attach the wires to the screw terminals.

FIG. 2: XMS OVERVIEW

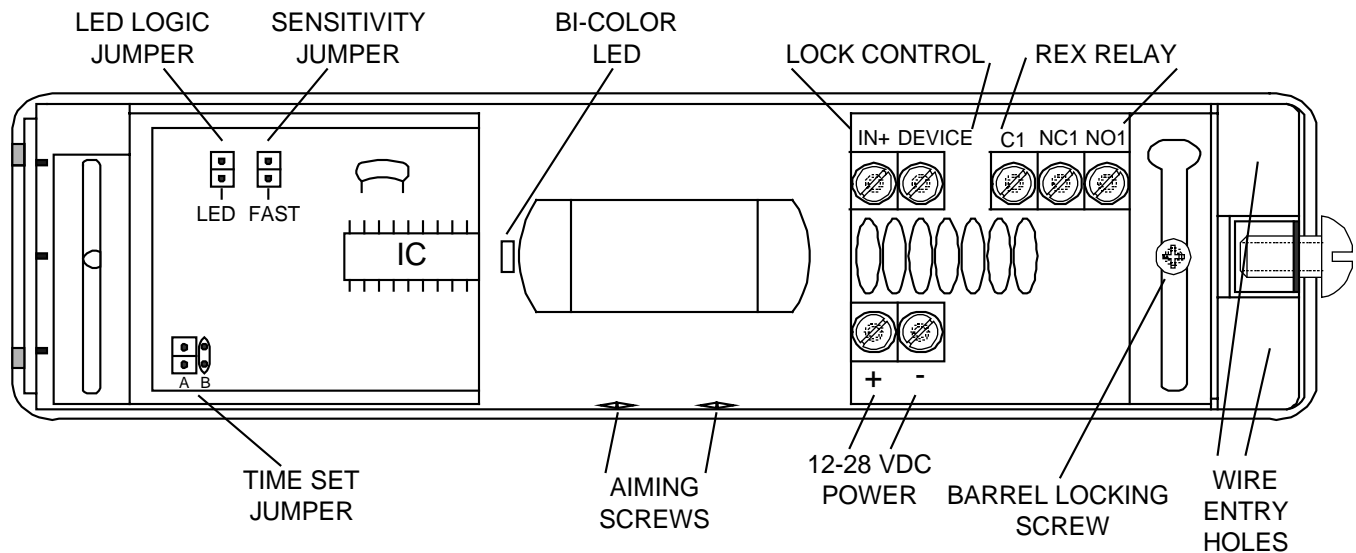

3. WIRING

3.1 INPUT POWER

To power the unit, DC voltage between 12 and 28 volts should be applied to the power in terminals (see Figure 2). This connection should be **permanently** made to the power supply rather than switched through some other device. The XMS should receive **constant power**. Make sure you observe correct polarity with this connection. If you reverse the input power polarity, the unit will not be damaged but will appear to be dead. **Regulated DC power is not required**. A transformer + bridge rectifier (called full wave rectified DC or pulsating DC) is acceptable. Power consumption for the XMS is approximately **20 mA**.

3.2 WIRING WITH MAGNETIC LOCK ONLY

This is the simplest application which releases the magnetic lock from the inside for free egress but is not concerned with shunting any alarm point at the door. It is shown in Figure 3.

FIG. 3: WIRING WITH MAGNETIC LOCK ONLY

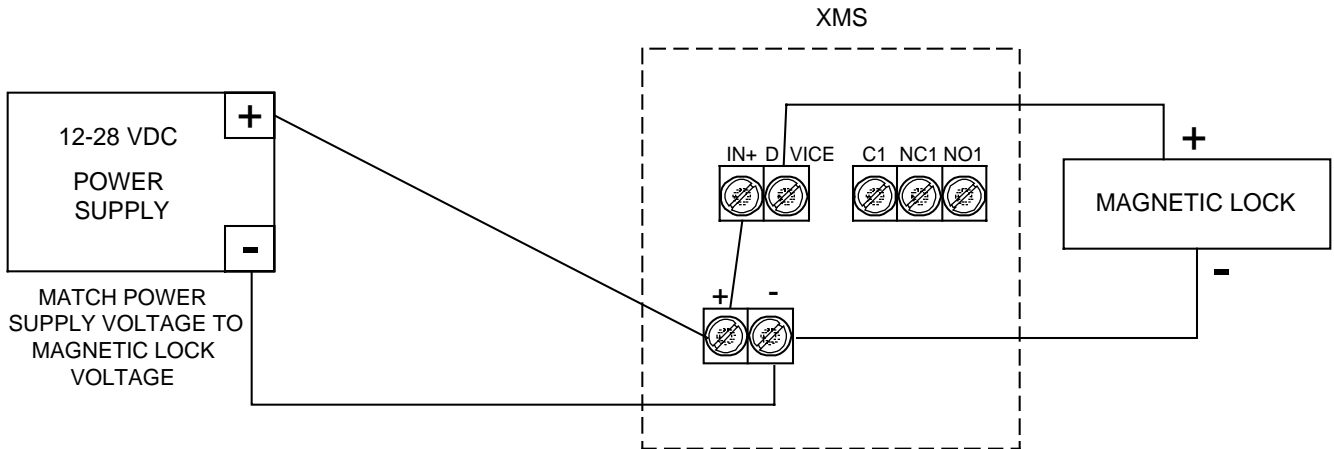

Note that how positive power to the lock connects through the terminal block “IN+” and “DEVICE”. These two terminals constitute an internal field effect transistor which does the actual switching. If power to the XMS was somehow interrupted, the field effect transistor would automatically open (releasing power to the lock). This makes the XMS “fail safe”. **Note: never use the REX relay contacts to switch the magnetic lock.** These contacts only have enough capacity for signaling; they cannot reliably switch magnetic lock current.

If you need to **integrate a controlled entry unit** such as a digital keypad, use a set of NC contacts from the entry unit to break the wire between “DEVICE” and magnetic lock “+” to allow the entry unit to release the lock.

3.3 SHUNTING AN ALARM POINT

This technique is for installations where the door is **connected to an alarm system** and that if the door opens without the XMS having been activated, an alarm signal should result. When the XMS is employed to open the door, the alarm signal should be shunted.

FIG 4: WIRING TO SHUNT ALARM SYSTEM ON DOOR

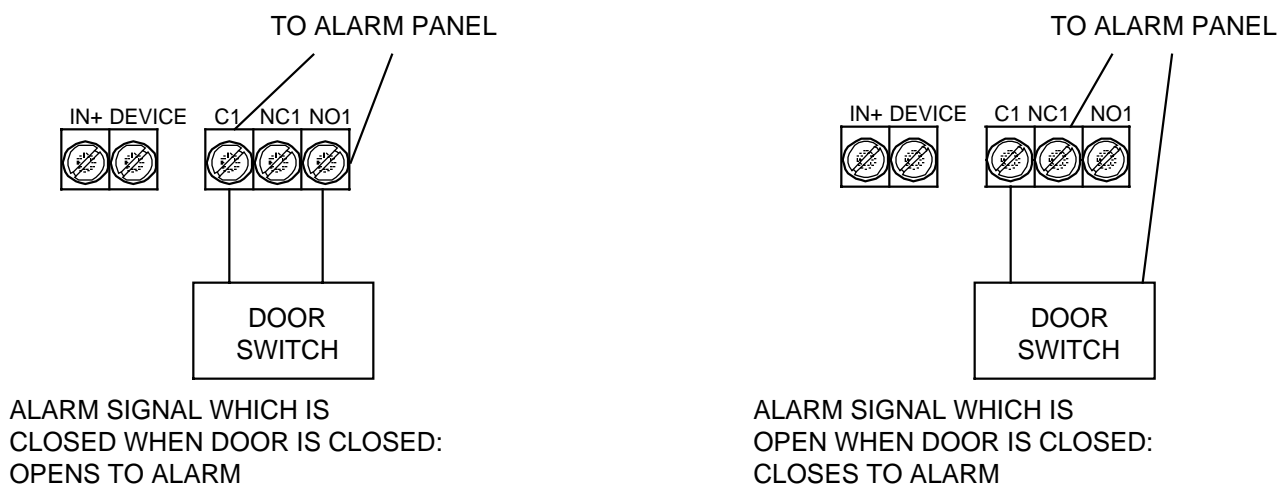

The alarm system will be connected to a door switch or other detector at the door via two wires. You will need to determine if this “loop” is closed when the door is closed and opens when the door opens or is open when the door is closed and closes when the door opens. Correct wiring to shunt the alarm is shown in Figure 4 for either instance. You utilize the “REX” relay contacts for this shunting while the lock control relay contacts continue to release the magnetic lock.

3.4 INTEGRATION WITH ACCESS CONTROL SYSTEM

An access control system permits entry (generally from a card reader) and will also often act as an alarm system if a door is forced. To integrate with the XMS and a magnetic lock, the access system should have a two-terminal REX (request to exit) input. When this input is closed, the access system will operate its lock control relay to release the lock and will not create an alarm signal as it will consider the exit event a “legal” one. Wiring is shown in Figure 5. Note that with this wiring method, the lock control terminals of the XMS directly break power to the magnetic lock as do the access system contacts. This is called “double break” wiring. It enhances safety and reliability as if the access system experiences a fault, the XMS still allows safe egress. If the access system is not monitoring the door, connection to the REX input is not required. In that case, make all other connections as shown in Figure 5 except the REX input.

FIG. 5: WIRING WITH AN ACCESS CONTROL SYSTEM

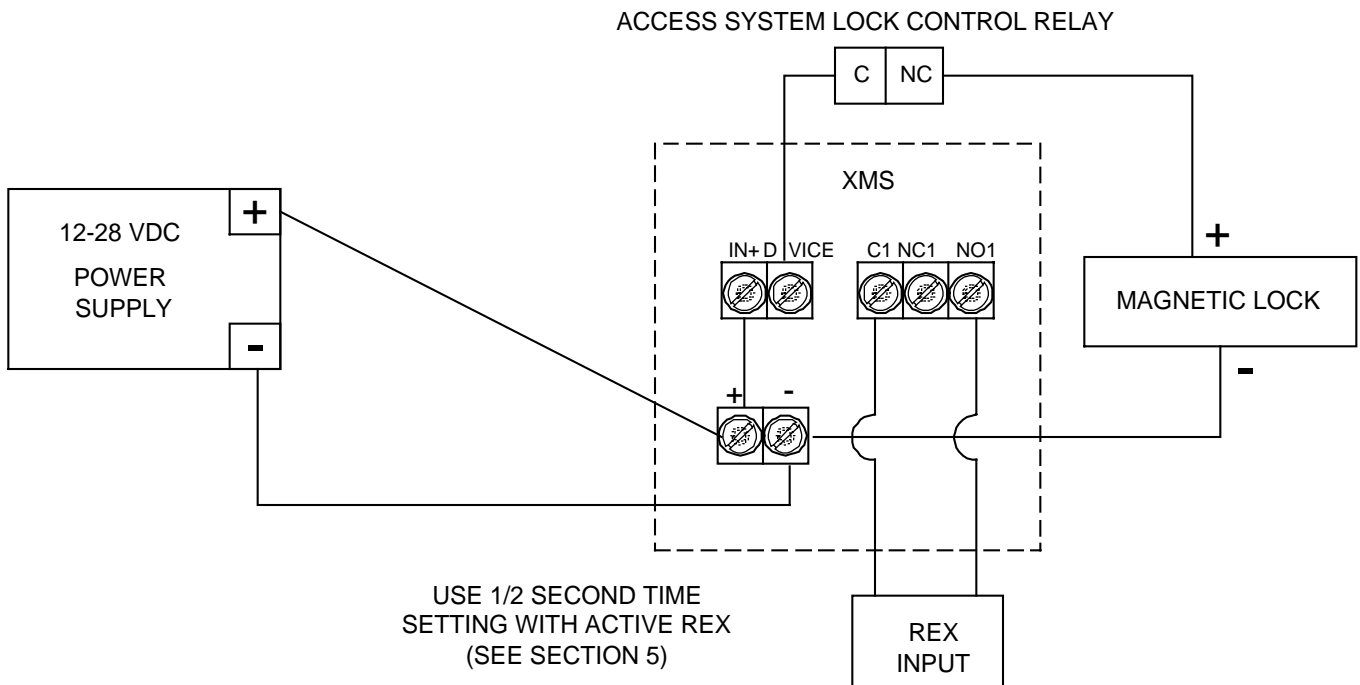
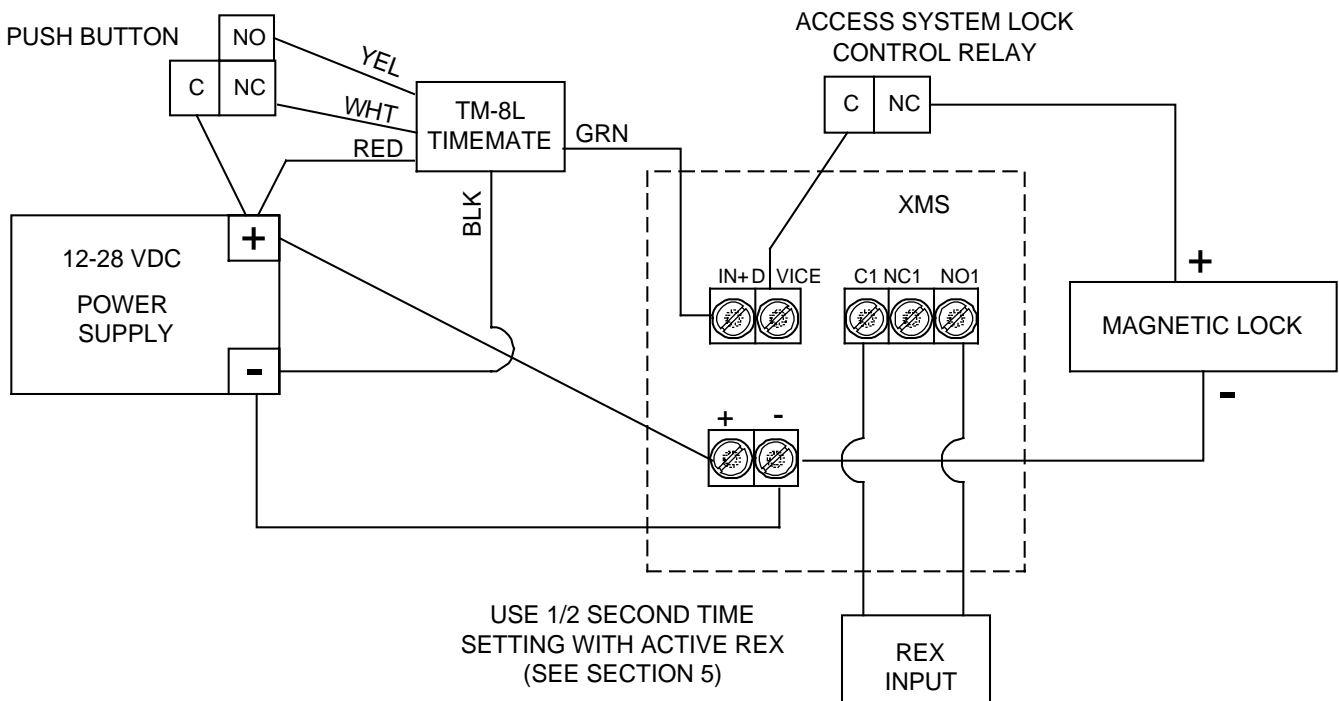

FIG. 6: WIRING WITH “GENERIC” PUSH BUTTON AND TIMER



3.5 “ACCESS CONTROLLED EGRESS DOOR”

In some jurisdictions, the combination of a magnetic lock, access control system and exit detector such as the XMS can be considered an “access controlled egress door”. The applicable section of the Life Safety Code calls for a redundant means of exit in the event of a problem with the detector. This is typically a push button located 40-48” above the floor and within five ft. of the door. Pushing the button will directly release power to the magnetic lock and the lock shall remain released for 30 seconds. This can be accomplished with any of Securitron’s push buttons and the model TM-8L timer. Figure 6 shows proper wiring.

Securitron also manufactures a line of **push buttons with integrated timers** (EEB2 and EEB3N). These are easier to use with the XMS to satisfy the code requirements for access controlled egress doors. Figure 7 shows wiring with the integrated push button/timers.

FIG. 7: WIRING WITH INTEGRATED PUSH BUTTON AND TIMER (EEB2, EEB3N)

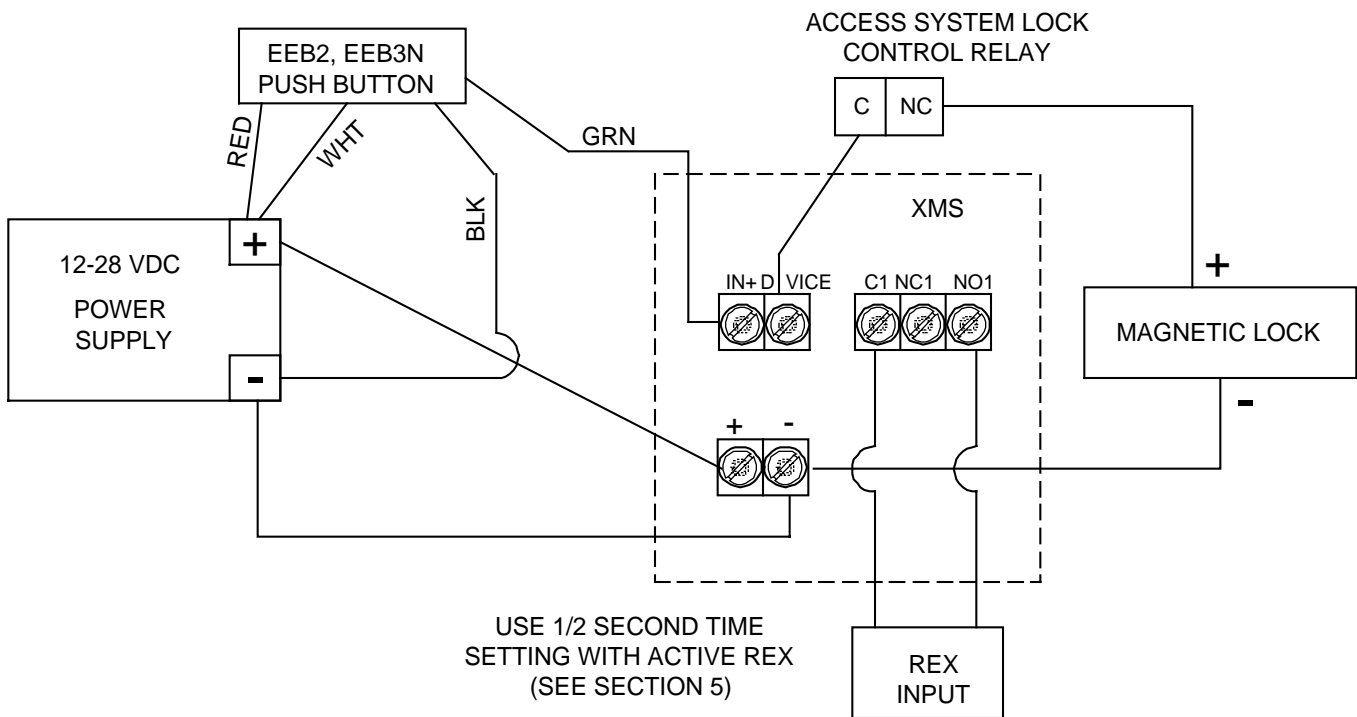

4. BASIC OPERATION

When the XMS is first powered, its LED will flash twice quickly every second for about 40 seconds. This is a **self test** and also permits the XMS to adjust itself to the thermal environment that it “sees”. After this start up period, the LED will stay green. If the self test fails during the start up period, the LED will begin to flash at four times per second. This failure indication will continue indefinitely. If you see it, de-power the unit for about 30 seconds and then re-power it. If the failure indication occurs again, **replace the unit**. During the self test period the unit’s control outputs are in their “normal” conditions (lock control-conducting; REX-relay deenergized).

In the event of a very brief power outage, the unit will not self test for 40 seconds but will undergo a self test of 10 seconds before resuming normal operation. Note that the self test on power up feature of the unit is the main reason why the XMS must receive **constant power**.

With the jumpers in factory set condition and the unit past its self test, it will detect moving objects at a different temperature than ambient. It will signal this detection by switching its LED from green to red. The LED actually mirrors the state of the REX relay rather than the lock control transistor.

You need to understand how the unit’s control outputs operate in a detection event. In the rest condition (green LED on; no detection), **the lock control transistor is conducting and the REX relay is deenergized**. When an object is detected, the REX relay energizes immediately. This is to shunt alarm contacts or send a REX signal to an access control system. **Fifty**

milliseconds later, the lock control transistor switches off which releases the magnetic lock. This brief delay is to make sure that the access control system has processed the REX signal so that it won't alarm if it is also reading lock status detection such as Securitron's Senstat feature. A lock status signal will change state as soon as the lock is de-powered.

In factory set condition, the lock control transistor will remain off for four seconds after detection has ceased (keeping the lock released). If, during the four seconds, the object moves again, the detection condition will be maintained for another four seconds after this "new" detection ceases. For the magnetic lock to resecure, **four seconds must pass with no detection**. This trailing edge timing feature is for egress safety and reliability. Otherwise, it is possible for a person to approach the door (thereby activating the XMS) but then stop moving for a brief moment at the door. The detector would then reset and if the person then quickly lunged into the door he could receive a bump as his motion could be quicker than the response of the detection to this new movement. The four second timing feature virtually eliminates this potential problem. Another operational safety feature is the fact that **if power is cut to the XMS**, the lock safely releases so that a person wishing to exit is not trapped.

Returning to operation of the REX relay, as we said earlier, it energizes 50 milliseconds before the lock control transistor releases the lock. It remains energized as long as the lock control transistor is continuing to release the lock. When the lock resecures, the REX relay will remain energized for one additional second to allow the magnetic lock to fully engage and report secure in the event that it is reporting lock status to an access control system.

FIG. 8: OPERATIONAL TIMING CHART FOR XMS

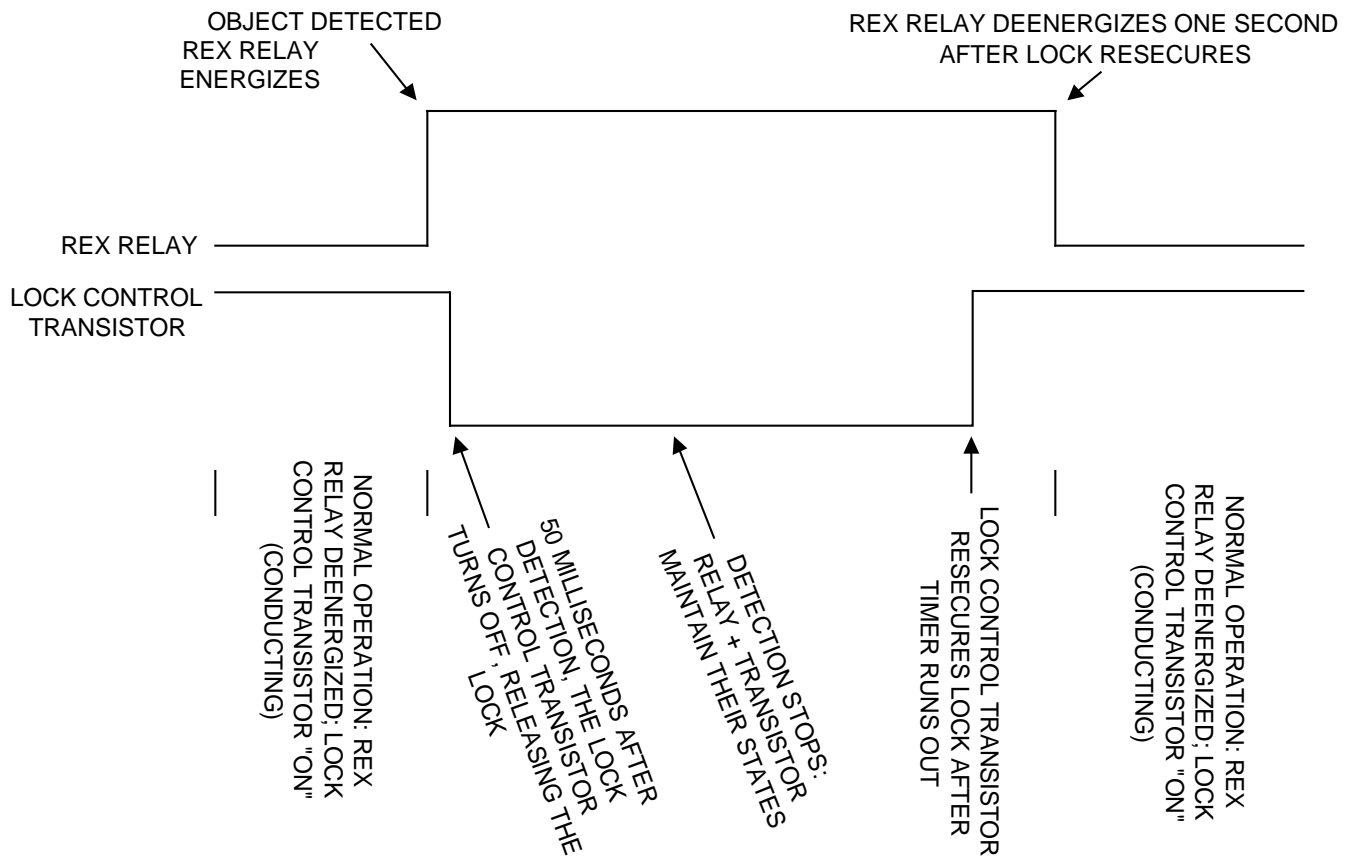

The four second timing feature of the lock control relay can be altered by changing jumper settings (see Section 5) but the REX relay always operates 50 milliseconds before and one second after the lock control transistor. Figure 8 shows the timing sequences.

5. JUMPER SETTINGS

Refer to Figure 2 and note that there are 3 jumpers. They are depicted in factory set condition.

The **LED logic jumper** controls the logic of the bi-color LED. When left in factory set position (jumper installed), the LED will illuminate red during a detection event and return to green in the rest condition. Removing the jumper will reverse these colors.

The **sensitivity jumper** makes the unit sensitive to movement in the factory set condition (jumper installed). It will become less sensitive when the jumper is removed. This is

sometimes advised when the unit is mounted with a loosely fitting door that leads to the exterior of the building. **If air, at a different temperature from the interior, is able to blow in from the gaps in the loosely fitting door, the XMS may “see” this.** The lock will therefore be occasionally released with no one present. Removal of the jumper can correct the problem at the cost of a bit slower operation. Other techniques include physically locating the unit farther from the edges of the door and adding weather-stripping to the door.

The **time set jumper** can be installed in any of three positions to alter the factory set trailing edge delay of four seconds. The drawing to the right shows the three choices. **Four seconds** is right for most applications. **1/2 second** is used for pattern set-up (see Section 6) and certain applications where an external timer should replace the XMS timer. For example, **when the XMS is integrated with an access control system** (see Section 3.4), the XMS’s REX relay will trigger the access system’s lock control relay and the magnetic lock will release for the same amount of time that is programmed for entry. Assuming the person does not immediately exit but moves around in front of the door, he will generate a series of 1/2 second REX signals but the REX timing function in the access system will retrigger each time so that the door will remain safely released. If you used the four second setting on the XMS for integration with an access control system, you would risk the following problem. On initial detection, the access system starts timing for 10 seconds (as an example) But the person does not immediately exit but moves around in front of the door so that the XMS signal does not change but stays closed because of the four second timing function. This allows the access system’s 10 second timer to time out and if the door is then used, a “forced door” alarm signal will result. So the 1/2 second setting is right for integration with access control systems.

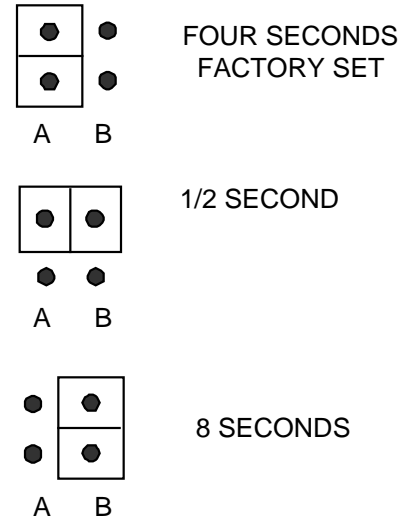

Another application where you should employ the 1/2 second setting is when the XMS is employed to initiate **delayed exit** when you are using Securitron’s model **XDT** timer.

The eight second setting is rarely used unless there is strong concern for maximum time being allocated for egress even when movement is not maintained. The problem with an eight second trailing edge delay is that entry security begins to be compromised by the door remaining open for this length of time following exit.

6. DETECTION PATTERN SET-UP

At this point in the installation, the unit should be physically mounted and wired. You should have also considered changing the jumper settings. Your final step is to adjust the detection pattern for the optimum combination of egress safety and entry security. Before doing this, **set the time set jumper to the 1/2 second position** (shown in the drawing to the right). As you are adjusting the pattern, you will make many quick tests of the unit and this will be most efficient if you don’t have to wait for a four or eight second trailing edge timer to expire.

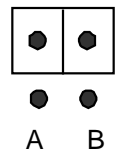

The XMS provides two means of adjustment. First, the entire barrel assembly rotates 90 degrees so that the unit can look “out” or “down”. Second, aiming screws (see Figure 2) are provided to laterally control the pattern. To access the aiming screws, the barrel assembly must be rotated so that the unit looks “out” so while you are making these adjustments, you will need the barrel locking screw (see Figure 2) to be loose.

In most applications, the unit is set to look “down”. The exception would be if the XMS was mounted on a wall perpendicular to the door rather than parallel to it. As the detection pattern proceeds outward from the XMS it spreads. We are talking here about spreading in the same direction as the barrel rotation rather than lateral spreading which is constrained by the aiming screws. The drawing on the right provides an example of this spreading. Assuming the XMS is mounted seven feet above the floor, the pattern will spread out roughly three feet by the time it reaches the floor. **Maximum detection distance** is approximately **20 feet**.

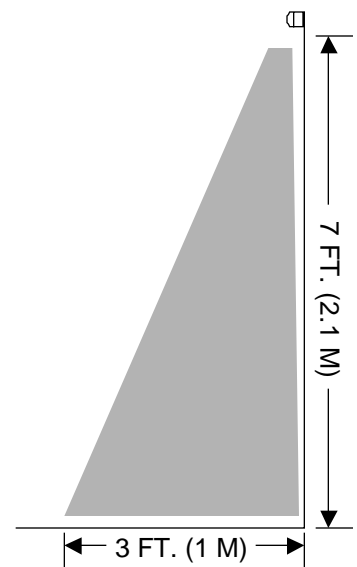

The **aiming screws** are used as follows. They control internal louvers that point the same way as the slots in the screws. When adjusting these screws, do not turn them past the point where you feel resistance as they can take the louvers "off track". Figure 9 shows the typical relationship between the aiming screw orientation and the resultant detection pattern.

To set your pattern laterally, experiment with the aiming screws as is shown in Figure 9. Each time you alter the aiming screw setting, you will have to rotate the barrel assembly up and down. Test the pattern by moving in it and observing the limits of detection by watching the LED. When you are satisfied with the aiming screw settings, you must also finalize the degree of barrel assembly rotation. You don't want the unit "seeing" the surface of the door itself as this can lead to false detection, so in the common case where the unit mounts in the same plane as the door, you do not want the barrel assembly adjusted at full 90 degrees. It should face slightly away from the door.

When you are entirely satisfied, be sure to tighten the barrel locking screw and restore the time set jumper to the four second position (if necessary). Then replace the cover.

FIG 9: USE OF THE AIMING SCREWS

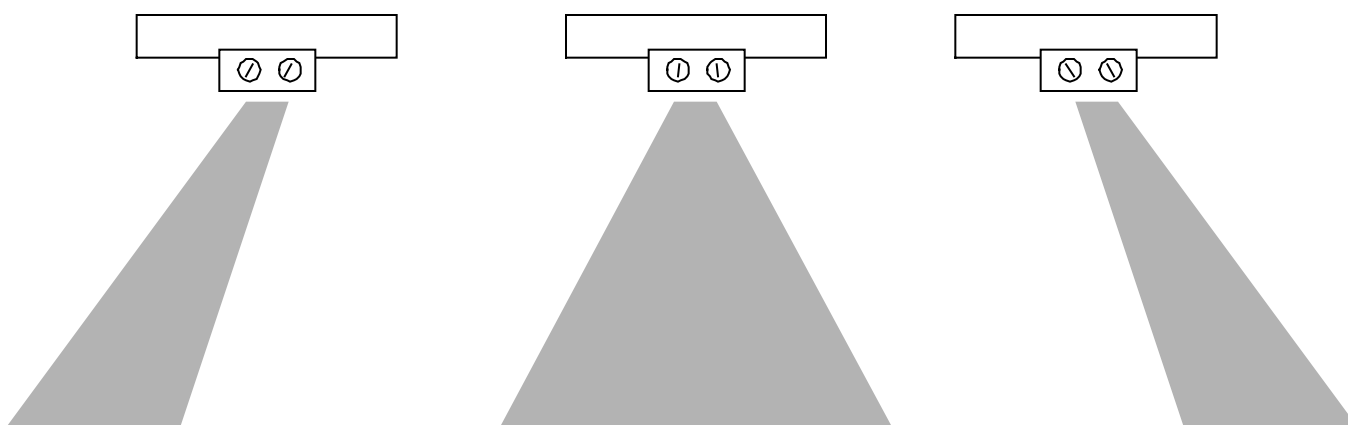

MAGNACARE LIMITED LIFETIME WARRANTY

SECURITRON MAGNALOCK CORPORATION warrants that it will replace at customer's request, at any time for any reason, products manufactured and branded by SECURITRON.

SECURITRON will use its best efforts to ship a replacement product by next day air freight at no cost to the customer within 24 hours of SECURITRON's receipt of the product from customer. If the customer has an account with SECURITRON or a valid credit card, the customer may order an advance replacement product, whereby SECURITRON will charge the customer's account for the price of the product plus next day air freight, and will credit back to the customer the full amount of the charge, including outbound freight, upon SECURITRON's receipt of the original product from the customer.

SECURITRON's sole and exclusive liability, and customer's sole remedy, is limited to the replacement of the SECURITRON product when delivered to SECURITRON's facility (freight and insurance charges prepaid by customer). The replacement, at SECURITRON's sole option, may be the identical item or a newer unit which serves as a functional replacement. In the event that the product type has become obsolete in SECURITRON's product line, this MAGNACARE warranty will not apply. This MAGNACARE warranty also does not apply to custom, built to order, or non-catalog items, items made by others (such as batteries), returns for payment, distributor stock reductions, returns seeking replacement with anything other than the identical product, or products installed outside of the United States or Canada. This MAGNACARE warranty also does not apply to removal or installation costs.

SECURITRON will not be liable to the purchaser, the customer or anyone else for incidental or consequential damages arising from any defect in, or malfunction of, its products. SECURITRON does not assume any responsibility for damage or injury to person or property due to improper care, storage, handling, abuse, misuse, or an act of God.

EXCEPT AS STATED ABOVE, SECURITRON MAKES NO WARRANTIES, EITHER EXPRESS OR IMPLIED, AS TO ANY MATTER WHATSOEVER, INCLUDING WITHOUT LIMITATION THE CONDITION OF ITS PRODUCTS, THEIR MERCHANTABILITY OR FITNESS FOR ANY PARTICULAR PURPOSE.